



Lifting Eye Nut RUD RM

Product information

Octagonal lifting eye approved for lifting. Lifting with an angle of inclination is allowed with reduction of WLL (see diagram at blueprint) but we strongly recommend to use the Rud RM lifting eye only for straight lifting.

Applied harmonized norms: DIN EN ISO 12100: 2011-03

Material: Forged high tensile steel.

Marking: According to standard, CE-marked

Temperature range: -40° up to 200°C (no reduction of WLL)

Standard: EN 1677-1

Warning: RUD RM eye nuts are only to be used with bolts or threaded studs with a min. quality class 8.8 and who are 100 % crack detected. Non certified bolts or threaded studs are not allowed.

Safety factor: 4:1

Grade: 8

Part Code	WLL ton	Thread mm	WLL 90° ton	A mm	B mm	C mm	D mm	E mm	T mm	Weight kg	Delivery time
11.4055254	0.4	M6	0.1	12	11	10	25	25	34	0.1	12
11.4055255	0.8	M8	0.2	12	11	10	25	25	34	0.1	12
11.4055258	1	M10	0.25	12	11	10	25	25	34	0.1	12
11.4055271	1.6	M12	0.4	14	13	12	30	30	41	0.2	12
11.4055281	3	M14	0.75	16	15	14	35	35	48	0.3	12
11.4055460	3.2	M16	0.8	16	15	14	35	35	48	0.3	12
11.4055342	4.8	M18	1.2	18	17	16	40	40	55	0.4	12
11.4055343	6	M20	1.5	18	17	16	40	40	55	0.35	12
11.4055387	6	M22	1.5	22	21	20	50	50	70	0.65	12
11.4055394	8	M24	2	22	21	20	50	50	70	0.6	12
11.4055399	8	M27	2	28	26	24	60	60	85	1.4	12
11.4055438	12	M30	3	28	26	24	60	60	85	1.3	12
11.407994437	12	M33	3	37	43	38	90	100	130	5.8	12
11.4053093	16	M36	4	40	43	38	90	100	130	5.65	12
11.407904790	20	M39	5	37	43	38	90	100	130	5.65	12
11.4053095	24	M42	6	40	43	38	90	100	130	5.4	12
11.4053098	32	M48	8	40	43	38	90	100	130	5.3	12

Blueprint

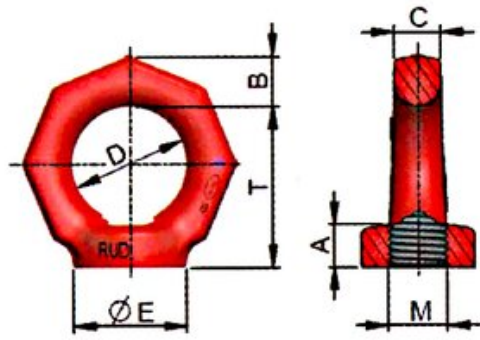

Lifting Method					
Angle of inclination β	0°	90°	0°		
WLL Factor	1	0.25	2		
For these lifting methods we recommend lifting points which can be adjusted to the direction of pull!					