

Elektric wormgear winches

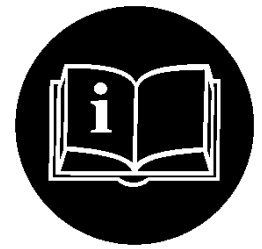

**EW125-250-500-990-1000-2000-D/230V**

**EW125-250-500-990-1000-2000-3200-D/400V**

---

## **Installation,- Operating and Maintenance Instructions**

**GEBUWIN**  
quality winches



*Scan to download all  
other documents*



Note: this document is translated from the original language Dutch - subject to alterations and linguistic errors

**Gebuwin B.V.**  
Industrieweg 6  
7102 DZ Winterswijk  
The Netherlands  
(+31) 543 532 600  
info@gebuwin.com

## CE-DECLARATION CE-VERKLARING

Gebuwin B.V. hereby declares, that the design, construction and commercialised execution of the below mentioned product(s) complies with the essential health and safety requirements of the CE Machinery Directive (2006/42/EG). The validity of this CE-declaration will cease in case of any modification or a supplement not being agreed with us previously. Furthermore, validity of this declaration will cease in case that the machine will not be operated correctly and in accordance to the operating instructions and/or not be inspected regularly.

*Hiermede verklaart Gebuwin B.V., dat het ontwerp, constructie en uitvoering van de hieronder vermelde product(en) voldoen aan de toepasselijke veiligheids-, en gezondheidseisen van de CE-markering machinerichtlijn (2006/42/EG). De geldigheid van deze verklaring eindigt indien er een verandering of toevoeging heeft plaatsgevonden welke niet met Gebuwin is afgestemd en in het geval van niet juist of incorrect gebruik van het product en het niet uit voeren van de vereiste controles.*

---

<b>Product</b> Product	Hand driven worm- and spur gear winch <i>Hand aangedreven worm- en tandwiel lier</i>
<b>Type</b>	EW125../..,EW250../..,EW500../..,EW990../..,EW1000../..,EW2000 D/230V EW125../..,EW250../..,EW500../..,EW990../..,EW1000../..,EW2000../..,EW3200 D/400V
<b>Serial no.</b> Serie nr.	Serial numbers for the individual capacities are registered in the CE production book <i>De serienummers van de afzonderlijke capaciteiten zijn geregistreerd in het CE-productieboek</i>
<b>Relevant CE directives</b> Relevante CE richtlijn	EC-machinery directive 2006/42/EC (Appendix II A) <i>CE-markering machinerichtlijn 2006/42/EG (Appendix II A)</i>
<b>Relevant EC Directives:</b>	EC-machinery directive 2006/42/EC (Appendix II A), Low voltage directive 2014/93/EC, Directive electro-magnetic compatibility 2014/35/EC
<b>Transposed standards:</b>	EN ISO 12100 Safety of machines - basic terms EN 13157, ISO 4301, DIN 15020 Cranes EN 14492 Cranes- power-actuated winches and hoists EN 818 Chains, EN 12385 Wire ropes EN 12195-3 Cargo locking for vehicle EN13001 Cranes general design, DIN 15020 Hoists FEM 9.511 Classification of FEM group

---

<b>Date</b>	01-01-2024
<b>Manufacturer</b>	Gebuwin B.V. Industrieweg 6 7102 DZ, Winterswijk The Netherlands

**Signature**



**Representative** R. Siertsema (Operational Director)





# 1 Information

Gebuwin products meet European Union requirements, in particular the EU Machine Directive (2006/42/EG).

The entire company works acc. to a certified quality assurance system as per ISO 9001.

The production of components at Gebuwin is subject to strict, intermediate checks.

After assembly, each Gebuwin product is subject to a final test with overload.

For the operation of hoists, the accident prevention regulations BGV D8, BGV D6 and BGR 500 apply in Germany, amongst others.

The stated performance of the devices and meeting any warranty claims require adherence to all instructions in this manual.

Before delivery, all Gebuwin products are packed properly. Check the goods after receipt for any damage caused during transport. Report any damage immediately to the forwarding agent.

This manual allows a safe and efficiently use of equipment. Images of this manual are for a principle understanding and can be different from the real design.

## **NOTE!**

We refer to the prescribed equipment tests before initial start-up, before putting back into operation and the regular periodic inspections.

In other countries any additional national regulations must be observed.

### 1.1 Indications to determine the used part of the theoretical usage life.

For motor driven units.

The equipment (rope hoists, chain hoists, winches as well as crane hoisting units) are classified in drive groups (duty classification) according to their intended mode of operation, running times and load collectives and dimensioned according to the requirements derived from these. (I.e. DIN 15020, ISO 4301/1, FEM 1.001, FEM 9.511). They are thus only designed for a limited period of use with regard to the overall dimensioning and certification.

After the total period of use as elapsed, measures must be taken where parts are checked and exchanged as per indication by the manufacturer. After that a new maximum usage period is determined. See also the accident prevention regulations BGV D 8, winches, lifting and pulling devices.

## **NOTE!**

### **Commitment**

A general overhaul may only be performed by Gebuwin or by a specialized company, authorized by Gebuwin.

## 2 Safety

### 2.1 Warning notice and symbols

Warnings and notice are shown as follows in these instructions:

 <b>DANGER!</b>	This means that there is a high risk that leads, if it is not avoided, to death or severe injury.
--	---

 <b>WARNING!</b>	This means that there is a risk that could lead, if it is not avoided, to death or severe injury.
---	---

 <b>CAUTION!</b>	This means that there is little risk that could lead, if it is not avoided, to slight injury or damage to the device or its surrounding.
---	--



#### **NOTICE!**

Gives advice for use and other useful information.



Danger from electricity.



Danger from explosive area.

### 2.2 Duty of care of the owner

The unit was designed and built following a risk analysis and careful selection of the harmonized standards that are to be complied with, as well as other technical specifications. It therefore represents state-of-the-art technology and provides the highest degree of safety.

Our delivery includes the hoist supplied beginning at its suspension and ending at the load hook and if supplied with control, the control line/hose that leads to the hoist. Further operating material, tools, load attaching devices as well as main energy supply lines must be assembled according to the valid rules and regulations. For explosion-proof equipment, all these parts must be approved for use in area prone to explosion, or they must be suitable for use in area prone to explosion. The owner is responsible for this.

However, in everyday operation this degree of safety can only be achieved if all measures required are taken. It falls within the duty of care of the owner/user of the devices to plan these measures and to check that they are being complied with.

Complete the operating and installation instructions by any instructions (regarding supervision or notifications) that are important for the special kind of use of the equipment, i.e. regarding organization of work, work flow and human resources.

In particular, the owner/user must ensure that:

- The unit is only used appropriately.
- The device is only operated in a fault-free, fully functional condition, and the safety components, in particular, are checked regularly to ensure that it is functioning properly.
- The required personal protective equipment for the operators, service and repair personnel is available and is used.
- The operating instructions are always available at the location where the equipment is used and that they are legible and complete.
- The unit is only operated, serviced and repaired by qualified and authorized personnel.
- This personnel is regularly trained in all applicable matters regarding safety at work and environmental protection, and that they are familiar with the operating manual and, in particular, the safety instructions it contains.
- Any safety and warning signs on the devices are not removed and remain legible.
- Devices for use in area prone to explosion must (from customer's side) be earthed with a shunting resistor of  $< 10^6 \Omega$  against earth.

 <b>WARNING!</b>
It is not allowed to make constructive changes of the equipment!

### 2.3 Requirements for the operating personnel

The units may only be operated by qualified persons that are appropriately trained and that are familiar with it. They must have their employer's authorisation for operation of the units.

Before starting work, the operating personnel must have read the operating and installation instructions, especially the chapter "Safety Instructions".

This is especially important for operating personnel that rarely uses the equipment, i.e. for installation or maintenance work.



## **DANGER!**

In order to avoid severe injury, please pay attention to the following when using the equipment:

- Use protective clothes/equipment.
- Do not wear long hair hanging down open.
- Do not wear rings or other jewellery.
- Do not wear cloths that are too big/wide.

## **2.4 Appropriate use**

The permitted safe working load of the devices must not be exceeded! An exception can be made during the load test, carried out by a licensed qualified person in accordance with the accident prevention regulations UVV BGV D6 before initial operation.

- The permitted environmental temperature during equipment operation is  $-20^{\circ}\text{C}$  up to  $+40^{\circ}\text{C}$ !
- Defective devices and load suspension devices must not be used until they have been repaired! Only original Gebuwin spare parts must be used. Non-compliance will result in any warranty claims on Gebuwin becoming void.
- Liability and warranty will become void if unauthorized modifications of the units are made by the user!

Vertical lifting and lowering of unguided loads, horizontal movement of loads and inclined movement of loads, movement of flaps, covers etc.

### **2.4.1 Winches with disengaging clutch (as option)**

- Only for pulling out the uncharged wire rope
- Only for horizontal load
- Only for special kinds of use (i.e. lowering of floaters in liquids) when there is no danger for persons or danger of damage of material.



## **NOTE!**

If the units are not used appropriately, it is not possible to ensure safe operation.

The owner and operator have sole liability for all personal injury and damage to property arising from inappropriate use.



## **DANGER!**

It is not allowed:

- pulling loose of stuck loads, dragging of loads and inclined pulling is not allowed.
- in explosive atmosphere, except the unit is especially modified for it and marked by an indication label
- to transport people
- persons must not stand under a suspended load

## 2.5 Basic safety measures

- Observe installation-, operation and maintenance instruction.
- Take notice of caution notes at units and in the manual
- Observe safety distances.
- Take care for a free view on the load.
- Only use the hoists appropriately.
- The equipment is to be used exclusively for movement of goods. Under no circumstances may persons be moved.
- Never load the devices beyond their working load limit.
- Pay attention to the accident prevention regulations (UVV).
- Should the hoist be used outside of Germany, please pay attention to the national regulations that apply.
- Supporting structures and load-attached devices used in conjunction with this equipment must provide an adequate safety factor to handle the rated load plus the weight of the equipment. In case of doubt, consult a structural engineer.
- If the equipment has not been used for a period of time, carry out visual checks of all main components such as chains, load hooks etc. and replace any damaged parts with new, original spare parts before putting the equipment back into operation!
- Do not use a hoist that is defective, pay attention to any abnormal noise it makes during operation.
- Stop working immediately in case of disturbances and remedy failures.
- Any damage and faults must be reported to a responsible supervisor immediately.
- If the unit is put into motion, any persons in the immediate vicinity must be informed by calling to them!
- Please pay attention to the regulations for load carrying devices UVV BGR500 for both positive and non-positive methods of attaching loads.
- The lifting tackle or the load must be securely attached to the hook and be seated at the bottom of the hook.
- The safety catch of hooks must be closed.
- When charged, the housing may not be in contact somewhere.
- Check brakes daily before commencing work.
- The devices are not suitable for continuous operation. The duty cycles of the motors (see the technical data chapter) as well as the remaining life time of the equipment in accordance with FEM group and usage (see calculation of remaining safe working period) must be observed.



### **WARNING!**

The following is not allowed:

- to lift another load than the nominal safe working load
- The use of elongated or damaged chains or wire ropes. Replace them immediately by new, original parts.
- Never loop the load chain around a load nor place or pull the chain over edges.
- Never repair damaged load hooks (e.g. by hammering), but replace them by original hooks.

## 3 Transport and Storage



### CAUTION!

Transport may only be done by qualified personnel. No liability for any damage resulting from improper transport or improper storage.

### 3.1 Transport

Gebuwin devices are checked and if so adequately packed before delivery.

- Do not throw or drop the equipment.
- Use adequate means of transport.

Transport and means of transport must be suitable for the local conditions.

### 3.2 Safety device for transport



### NOTE!

Should a safety device for transport exist, please remove it before commissioning.

### 3.3 Storage

- Store the equipment at a clean and dry place.
- Protect the equipment against dirt, humidity and damage by an appropriate cover.
- Protect hooks, wire ropes, chains and brakes against corrosion.



## 4 Description



### 4.1 Areas of application

The devices must be as far as possible installed in a covered room.

If they are used in the open, protect the units against the effects of weather such as rain, hail, snow, direct sunshine, dust, etc. - we recommend to use a cover in parking position. If the device is set up in a continuously humid environment with strong temperature fluctuations, the correct functioning of the motor and the brake are endangered by the forming of condensation.

Ambient temperature: - 20°C up to + 40°C. Humidity: 100 % or less but not under water

During longer periods of standstill, corrosion may reduce the function of the brake.

	 <b>DANGER!</b>
	It is not permitted to use the unit in an area at risk from explosion!

### 4.2 Design

Gebuwin electric wire rope winches for stationary use are fitted with holes for installation. The housing is made of steel plate. The two housing halves are connected by threaded bolts and distance tubes. The rope drum between the two housing halves offers wire rope exits in several directions. Different installation positions are possible, - make sure the drum axle is always positioned horizontally.

Available for single phase current or 3-phase current.

Single phase current



3-phase current



#### 4.2.1 Wire rope exit

For winches with ungrooved drum the rope can be wound round the drum in both directions.

In case of changes of the winding direction of the wire rope, electrical wiring must also be changed according to the wiring diagram.

Winches with grooved rope drum and winches with overload protection (serial equipment for 1000 kg and up) are supplied with rope exit direction A.

rope exit direction A

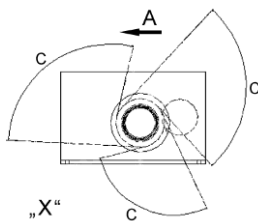

rope exit direction B

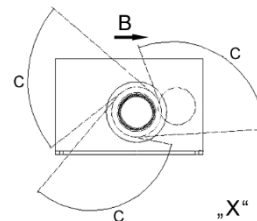

The direction of rope exit for winches with grooved rope drum is determined by the grooves and by the overload protection, if existant.

Winches from 250 kg capacity and up are optionally available with disengaging clutch. This may be advantageous in cases where to load is pulled horizontally and afterwards the wire rope should be pulled off the drum quickly by hand.

#### **NOTE!**

For winches with grooved drum the direction of unwinding the wire rope cannot be changed afterwards.

### 4.3 Functions

The lifting gear are operated by pressing the push buttons on the control switch. The spring-pressure brake installed in the electric motor of the lifting gear prevents the independent lowering of the load after the push button has been released.

### 4.4 Important components

#### 4.4.1 Hoist motor

Optionally available for 3-phase current 400 V/50 Hz or A.C. 230 V/50 Hz.

Other voltages and frequencies can be supplied on request.

#### 4.4.2 Hoist gear

125 kg worm gear

250 - 3200 kg worm gear with additional spur wheel pair

For winches from 1000 kg and up - the sealing screw of the gear must be exchanged before first start up by the ventilation screw.

#### 4.4.3 Overload protection by current cut-off

Winches from 1000 kg pulling rope force and up (for 125-990 kg as option) are fitted with an electronic overload protection. It is adjusted by the manufacturer according to the regulations that apply. The overload protection prevents lifting a load that is too heavy by switching off the hoisting motor. When putting the winch into operation or after current of the winch has been cut off or after the overload protection has operated, press the button "lowering" shortly to re-activate the relay. A re-adjustment i.e. for maintenance reasons is possible.

#### 4.4.4 Limit switch for wire rope path (as option)

The switch limits the wire rope path in 1st layer for grooved drum.

Function: Operational and emergency limit switch.

It is possible to connect an external electric limit switch.

#### 4.4.5 limit switch

To stop the wire rope path.

Serial winch is a lifting winch.

Pulling winch as option.

Function: Operational and emergency limit switch.

It is possible to connect an external electric limit switch.

#### 4.4.6 Overload protection by current cut-off

Serially fitted with electronic overload protection for units of 1000 kg and up.

Electronic overload protection for units up to 1000 kg available as option.

The overload protection is adjusted by the manufacturer according to the regulations that apply. The overload protection prevents lifting a load that is too heavy by switching off the hoisting motor. When putting the winch into operation or after current of the winch has been cut off or after the overload protection has operated, press the button "lowering" shortly to re-activate the relay. A re-adjustment i.e. for maintenance reasons is possible.

#### 4.4.7 Control

- Low voltage control (direct control depends on the kind of unit)
- Indirect control with phase sequence relay. The phases must be exchanged if the turning direction is wrong.
- Units with limit switch are fitted with low voltage control.
- Radio control is available as option.

#### 4.4.8 Control switch

- Control switch suitable for single hand use.
- The control switch housing is made of shock- and fracture-proof plastic.
- The control cable is fitted with stress-relief rope (not applicable for radio control).
- 2 step buttons for 2 wire rope speeds

#### 4.4.9 Disengaging clutch (as option)

- Not available for 125 kg capacity.

- For pulling out the uncharged wire rope.
- Disengagement operated by hand.

Unintended disengagement or disengagement by standard force effort is not possible under load.



## **DANGER!**

The following is not allowed:

- Disengaging under load.
- Manipulation of the disengaging device.

## 5 Technical data

3-phase current 400 V 50 Hz													
Capacity 1 <sup>st</sup> layer kg	Wire rope storage 1 <sup>st</sup> layer m	Wire rope speed 1 <sup>st</sup> layer m/min	Capacity top layer kg	Wire rope storage top layer m	Wire rope speed top layer m/min	rope layers number	nec. wire rope ø mm	nec. min. breaking load kN	FEM 9.511	Motor- output kW	Current con- sumption A	Noise emission * dB(A)	Weight without wire rope approx. kg
125	6,4 (5)	7,8	90	32 (30)	11	4	4	5	1 Bm	0,37	1,1	78	25
125	6,4 (5)	15	90	32 (30)	22	4	4	5		0,75	1,9	79	25
250	7,1 (5,6)	5	180	35(34)	7	4	4	9		0,37	1,1	78	35
250	7,1 (5,6)	10	180	35(34)	14	4	4	9		0,75	1,9	79	35
500	5,7 (4,8)	2,5	340	30 (29)	4	4	6	18		0,37	1,1	78	38
500	5,7 (4,8)	5	340	30 (29)	8	4	6	18		0,75	1,9	79	38
990	8,4 (6,8)	4,5	780	30 (29)	6	3	8	36		1,3	3,2	79	80
990	8,4 (6,8)	9	780	30 (29)	12	3	8	36		2,6	6	79	80
1000	8,4 (6,8)	4,5	780	30 (29)	6	3	8	36		1,3	3,2	79	80
1000	8,4 (6,8)	9	780	30 (29)	12	3	8	36		2,6	6	80	80
2000	8(6,3)	4,5	1560	30(28)	6	3	11	70		2,6	6	80	150
3200	9(8)	4,5	2500	37(36)	5,5	3	16	114		3	7	80	210

### A.C. 230 50 Hz

Capacity 1 <sup>st</sup> layer kg	Wire rope storage 1 <sup>st</sup> layer m	Wire rope speed 1 <sup>st</sup> layer m/min	Capacity top layer kg	Wire rope storage top layer m	Wire rope speed top layer m/min	rope layers number	nec. wire rope ø mm	nec. min. breaking load kN	FEM 9.511	Motor- output kW	Current con- sumption A	Noise emission * dB(A)	Weight without wire rope approx. kg
125	6,4 (5)	7,8	90	32 (30)	11	4	4	5	1 Bm	0,37	4	78	27
250	7,1 (5,6)	5	180	32(30)	7	4	4	9		0,37	4	78	37
500	5,7 (4,8)	2,5	340	30 (29)	4	4	6	18		0,37	4	78	40
990	8,4 (6,8)	4,5	780	30 (29)	6	3	8	36		1,75	11	79	88
1000	8,4 (6,8)	4,5	780	30 (29)	6	3	8	36		1,75	11	79	88
2000	8,0 (6,3)	2,3	1560	30(28)	3	3	11	70		1,75	11	79	160

Data for special design equipment are mentioned on the type plate.

Values in (...) are valid for grooved drum

\* measured at a distance of 1 m from the surface of the unit and 1,6 m over the assembly area (tolerance +2dB(A))

## 6 Installation

Please observe the following points in order to avoid any damage to equipment or injury of person:

- Wear safety gloves.
- Install the winch on a stable ground.
- Make sure attachment surface is flat and that installation is made stress-free, - use shim parts if necessary.
- The winch must be set up and attached in such a way that it cannot change position neither by the load nor by other influences.

### 6.1 Winch fastening – hole measures

Capacity 1st layer	screws number	anchoring screws ø D strength class 8.8	A mm	B mm	C mm	E mm
125	4	M 8	231	405	205	375
250	4	M 10	290	405	260	375
500	4	M 10	290	405	260	375
990	4	M 12	379	575	345	535
1000	4	M 12	379	575	345	535
2000	4	M 16	480	600	440	550
3200	4	M 16	565	600	525	550



Bild 1

### 6.2 Selection of wire ropes

- Wire ropes acc. to EN 12385-4 - Lifting ropes
- Stainless wire ropes and special wire ropes are available on request.
- Diameter and nec. minimum breaking load must be acc. to the data mentioned in the table in chapter "Technical Data" resp. acc. to the details mentioned on the type plate.

#### Recommendation of wire ropes

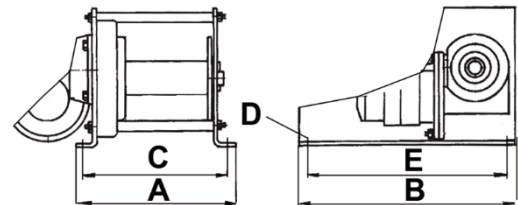
- Steel-reinforced wire ropes
- For larger pulling rope forces, fibre-core wire ropes can also be used.
- For unguided loads, - non-twisting or at least twist-resistant wire ropes.
- For several rope layers wound through the drum, - steel-reinforced wire ropes.



#### **WARNING!**

It is not allowed to use plastic wire ropes or plastic-coated wire ropes.

### 6.3 Wire rope fastening

If the winch is fitted with overload protection, the winding direction of the wire rope is determined.

Winding direction "A" is supplied as standard.

When the winding direction is changed, electrical wiring in the terminal box must be changed accordingly.

The kind of wire rope fastening and the winding direction are determined for winches with grooved drum by the direction of the grooves on the drum.

Before cutting the wire rope, wrap it firmly with a fine binding wire or strong adhesive tape.

#### 6.3.1 125 kg

- Fasten the wire rope with countersunk screw and clamping disc in the hub situated at the inner side of the big flanged wheel.
- In order to avoid any kinks of the wire rope take into consideration that the wire rope exit is correct when winding the rope onto the drum.

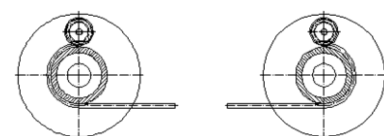

Illustration 2

### 6.3.2 250 kg - 3200 kg

The retainer key is attached to the consignment for winches supplied without wire rope.

- Push the wire rope through the hub of the flanged wheel and through the key pocket.
- Pull some centimeters out.
- Wrap it completely round the retainer key (1)
- and place it back into the key pocket.

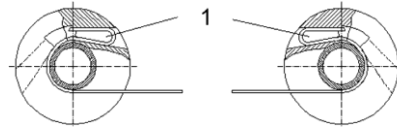

Illustration 3

By pulling the wire rope, the retainer key gets stuck into the pocket and locks the wire rope safely.

It may be necessary to insert the retainer key a little bit into the hub with a soft tool before the wire rope can be loaded.

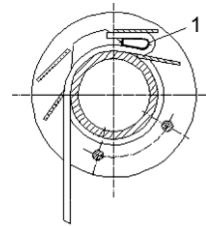

Illustration 4

### 6.4 Winding up of wire rope

The wire rope must always be wound up tensioned. When the last wire rope layer is wound onto the drum, the flanged wheel must exceed the top layer by at least 1 1/2 times of the wire rope diameter.

#### NOTE!

According to DIN 15020 regulations and to the accident prevention regulations BGV D8, the wire rope length must be chosen so that at least 2 rope layers remain on the drum when the wire rope is unwinded.

### 6.5 Wire rope deflection

- Wire rope pulleys must be installed in a position centrally to the rope drum.
- In order to ensure correct winding up of the wire rope on the drum, the max. wire rope deflection angle must not be exceeded.
- maximum wire rope deflection angle
  - 4° for standard wire ropes
  - 2° for non-twisting resp. twist-resistant wire ropes
- The minimum dimension (M) from the drum until the middle of the pulley must be adhered to.

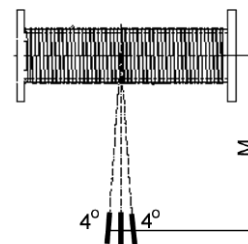

Illustration 5

#### NOTE!

Should the drum be extended and for some models with limit switch, the distance "M" must be increased. Standard values:

15x 1/2 drum length for standard wire ropes

30x 1/2 drum length for twist-resistant or non-twisting wire ropes





#### 6.5.1 Wire rope pulley (provided by the customer)

Table dimension "M" for standard drum length

Capacity kg	"M" min m
125	0.97
250	1.08
500	1.04
990	1.45

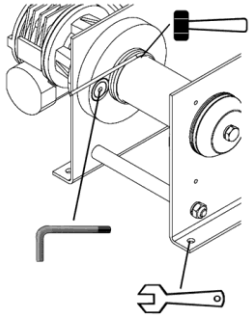
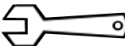
1000	1.45
2000	1.45
3200	1.85

## 6.6 Tools

Capacity	Size	Tool	Use	
125 kg	SW6		Rope fastening Clamp disc	
125 kg 250 + 500 kg 990 + 1000 kg 2000 + 3000 kg	SW13 SW17 SW19 SW24		Winch fastening	
	div.		Rope installation	
125 – 3000 kg	div.		div.	
125 – 3000 kg	div.		div.	
125 – 3000 kg	div.		div.	

## 6.7 Table of screws

Tighten the screws with tightening moment mentioned in the table

Thread	Tightening moment (Nm) in property class	
	<b>8.8</b>	<b>10.9</b>
M 6	10,4	15,3
M 8	25,3	37,2
M 10	51	75
M 12	87	128
M 14	139	205
M 16	214	314

M 18	280	390
M 20	431	615
M 22	530	750
M 24	742	1159
M 27	1000	1400
M 30	1350	1900
M 33	2000	2800

coefficient of friction 0,12 - 0,14  $\mu$ ges



## 7 Operation

Only people that are familiar with the operation of the lifting devices and cranes may be entrusted with their operation. They must be authorized by the employer for the operation of the equipment. The employer must ensure that the operating instructions are available near the equipment and that they are accessible for the operating personnel.

The shown control switches are only for the optical information. They can be different acc. the delivery.

### Pendant control lifting/lowering

- 1 Emergency-Stop
- 2 Lifting (slow - fast)
- 3 Lowering (slow - fast)

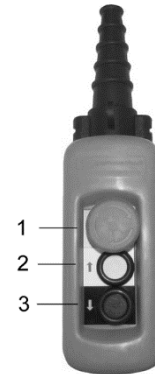

Illustration 6

### Pendant control – lifting/lowering

- 1 Emergency stop
- 2 Lifting (slow - fast)
- 3 Lowering (slow - fast)



Illustration 7

### Radio control

- 1 Lowering (slow - fast)
- 2 Lifting (slow - fast)
- 3 no function
- 4 no function
- 5 no function
- 5 no function
- 6 no function
- 7 no function
- 8 start
- 9 start
- 10 emergency stop



Illustration 8

## Push button functions

- Relieved push button = stand still
- push button half pushed = slow speed
- push button pushed completely = fast speed

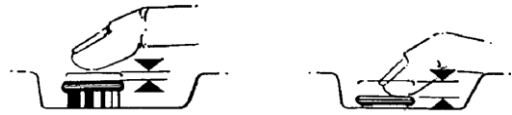

Illustration 9

## Red Emergency-Stop button

- button pushed = stand still
- turn the button clockwise = free functions

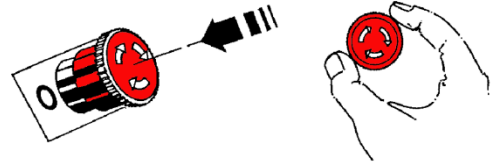

Illustration 10

## 7.1 Disengaging clutch (as option)

The drum is disengaged through a switch button situated at the gear shaft.

engaged (A)

disengaged (B)

- In order to release the switch, pull it out approx. 10 mm against the pressure of the spring (1) and turn it 90° to the left, - anti-clockwise (2).
- In this position there is situated a little slot where a dowel pin engages.
- Release the button

The drum is disengaged.

Engage (C)

- In order to engage the drum, pull the switch button out (1) and turn it 90° to the right, clockwise (3).
- Release the button
- In this position the dowel pin engages into the slot, - make sure that engagement is correct.

The drum is connected to its drive.

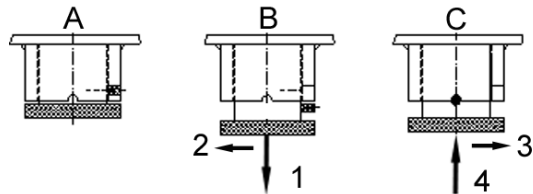

Illustration 11



## DANGER!

The following is not allowed:

- Disengaging under load.
- Manipulation of the disengaging device.

## 8 Operation

The following, important points must be observed when operating the equipment:

- Read the safety instructions.
- Never load the devices beyond their working load limit.
- When changing the motor turning direction, allow the motor to come to a standstill first.
- The prescribed maintenance intervals must be adhered to.
  
- Observe the duty cycle, i.e. intermittent operation S4-40% ED (as per VDE 0530) means that in a period of 10 minutes the motor can operate – no matter the height of the load – for 4 minutes. It is therefore irrelevant whether the 4 minutes are continuous (i.e., in case of very high lifting heights) or are made in intervals.



### **DANGER!**

It is not allowed:

- pulling loose or stuck loads, dragging of loads and inclined pulling is not allowed.
- in explosive atmosphere, except the unit is especially modified for it and marked by an indication label
- to transport people
- persons must not stand under a suspended load

# 9 Commissioning

## 9.1 General

Should the unit be used in Germany, please observe the accident prevention regulations, in particular BGV D8, BGV D 6 and BGR 500 (VBG 9a).

For other countries: Inspections as above. Please observe the national rules and regulations and the instructions in this manual!

### **NOTE!**

Hoists up to 1000 kg capacity and without motor-driven trolleys of hoisting unit must be tested by a "qualified person" before putting into operation for the first time.

Hoists of 1000 kg capacity and up or with more than one motor-driven hoist movement; i.e. lifting and trolley movement, must be tested by a "licensed quality person" before putting in operation.

An exception is "hoists ready for operation" acc. To BGV D6 II§25(4) with EU-declaration of conformity.

#### **Definition "qualified person" (former expert)**

A "qualified person" has learned, due to occupational training and experience and the job that the person has done, the skills needed to tests the material for one's work.

#### **Definition "licensed qualified person" (former approved expert)**

A "licensed qualified person" has, due through special occupational training, knowledge about testing of the material for one's work and knows the national accident prevention regulations and other prescriptions and technical regulations. This person must test the material for one's work regularly with regard to design and kind of use. The license will be given to qualified person be the approved supervision authorities (ZÜS).

## 9.2 Power supply

### 9.2.1 Mains connection

Hoist motor technical data can be found it in the "Technical data" chapter.

The following tables show the assignment of the wiring diagrams and the fuses at 400 Volt 3-phase current.

- Select connection cross-sections as per VDE 0100.
- Put sleeves on the ends of the cables.
- Insert the connection cable into the connection plug without strain.
- Secure lines as per VDE 0100.

### 9.2.2 Control line connection

Pendant with cable and plug-in connection. Plug-in before use.

Any changes of the power supply cable must only be effected by qualified personnel.

### 9.2.3 Power connection of the brake

The low-maintenance D.C. spring-pressure brakes are connected at the factory according to the wiring diagram.

### **NOTE!**

The power supply cable must be equipped by the customer with slow-blow fuses and mains connection switch.

### **CAUTION!**

Precondition for actuation of the overload protection is the correct winding direction of the wire rope!

This may be mixed up for winches with three phase current motor.

The symbols on the control switch than do not match to the wiring direction of the wire rope.

In this case, the winch must be stopped immediately.

Exchange two phases of the main current supply.

Test the winding direction of the wire rope.

### 9.2.4 Wiring diagram assignment

Capacity kg	Alternating current 230 V	drawing No.	3 phase current 400 V/ 50 Hz	drawing No.
----------------	------------------------------	----------------	---------------------------------	----------------

125-500	Direct control	5.56.287.21.00	Direct control	5.56.288.21.00
125-500	Direct control with limit switch	5.56.287.21.01	low voltage control with limit switch	5.56.288.21.01
990	Direct control	5.56.287.21.02	low voltage control with limit switch	5.56.288.21.02
990	Direct control with limit switch			
1000-3200	low voltage control with electric overload protection	5.56.288.21.67	low voltage control with electric overload protection	5.56.288.21.63
1000-3200	low voltage control with electric overload protection and limit switch	5.56.288.21.68	low voltage control with electric overload protection and limit switch	5.56.288.21.64

Wiring diagrams for special control are situated in the terminal box.

### 9.2.5 Assigning line cross-sections and fuses

Alternating current Motor output up to	slow-blow fuse	cable cross-section up to 100 m cable length	3 phase current Motor output up to	slow-blow fuse	cable cross-section up to 100 m cable length
1,3 kW	16A	1,5 mm <sup>2</sup>	3 kW	16A	1,5 mm <sup>2</sup>

### 9.3 Gear

Should the gear not be closed, the level of lubricant must be checked before putting the device into operation.



#### NOTICE!

For transport, some gear types are fitted with a plug screw. Replace the plug screw by a ventilation screw (attached) before putting the unit into operation.

### 9.4 Wire rope

Wire ropes must be free from corrosion, dirt or damage.

They must be lubricated before commissioning.

No lubrication shortens the lifetime of the wire rope and the maintenance intervals.



#### WARNING!

It is not allowed to use plastic wire ropes or plastic-coated wire ropes.

### 9.5 Limit switch for wire rope path

The limit switch (if exist) must be adjusted before commissioning and after maintenance work has been made. Intermediate checks for correct function are necessary.

The switching point for the upper load position must be set in such a way that even in case of unfavorable cable winding the permitted highest load position is not overrunned. In individual cases it may be necessary for the customer to install an external emergency switch. The limit switch for the lowest load position is always driven exactly independently of the cable length.



#### NOTE!

An exact driving up to the upper end position is only possible in the first wire rope layer with grooved rope drum.

Exactness decreases with larger wire rope length and several wire rope layers.

### 9.6 Slack rope switch (as option)

In case of slack rope i.e. by setting down of the load, the slack rope switch prevents further unwinding of the wire rope.

#### 9.6.1 Function

The weight of roller lever and guide pulley actuates rotation of the switching shaft with eccentric disc in case of slack wire rope. The eccentric disc pushes the switching pin of the limit switch down until the switching contacts in the circuit for "lowering" open.

Lowering without load is impossible.

Should this, however, be necessary i.e. during installation or adjustment work, the wire rope must be tensed by little load or the roller lever must carefully be actuated by hand. The switch can also be taken out of service by dismantling the eccentric disc.

The slack rope switch will be installed in our factory according to customer's requirements. Installation depends on the position of the winch and wire rope exit.

 **NOTE!**

Before commissioning, the switch must be adjusted by the customer.

The function is only possible in wiring direction "lowering". After the switch has actuated, "lifting" must still be possible.

## 10 Safety check

Before putting into service initially or when putting back into service, it must be checked whether:

- All fastening screws (if existent), socket pins, flap socket and safety devices are tightened and secured.
- The oil levels in the gear boxes are sufficient.
- All movements of the load comply with the symbols on the control switch.
- The wire ropes are winded up correctly, are lubricated and are in good condition.

## **11 Functional test**

### **11.1 Checks before the initial start-up**

- Check lifting by moving up/down and slow/fast without load.
- Suspend the nominal load and check the function of the brake.



## 12 Maintenance

### 12.1 General

All monitoring, servicing and maintenance operations are to ensure correct functioning of the equipment; they must be effected with utmost care.

- Only “qualified persons” may do this work.
- Servicing and maintenance work must only be done when the hoist is not loaded.
- Records must be kept of all test results and measures taken.

### 12.2 Monitoring

The monitoring and servicing intervals stated are valid for operation under normal conditions and single-shift operation. In case of severe operating conditions (e.g. frequent operation with full load) or special environmental conditions (e.g., heat, dust, etc.), the intervals must be shortened correspondingly

### 12.3 Brake motor

Brake: 180 V DC

Winch Capacity	Motor	Nominal brake moment	Nominal air gap	air gap max.	min.
kg		Nm	mm	Nm	mm
125-500	3 phase current	5	0.2	0.4	1,5 friction lining thickness
1000	3 phase current	15	0.3	0.45	1,5 friction lining thickness
2000	3 phase current	26	0.3	0.45	1,5 friction lining thickness
3200	3 phase current	32	0.3	0.7	8,0 rotor strength
125-500	Alternating current	5	0.2	0.8	7,5 rotor strength
1000-2000	Alternating current	16	0.2	0.5	7,5 rotor strength

#### 12.3.1 Assembling the brake

- 1 Insert the retaining ring (1) into the shaft slot.
- 2 Insert the feather key (2) into the motor shaft.
- 3 Fix hub (3) with retaining ring (1).
- 4 Assemble the friction plate (4) if existent.
- 5 Push the rotor (5) onto the hub (3).
- 6 Lock the magnet body with the 3 fastening screws (6).
- 7 Set air gap “a” (refer to “adjusting the air gap”)
- 8 Assemble the dust-protection ring (7) if existent.
- 9 Electric connection

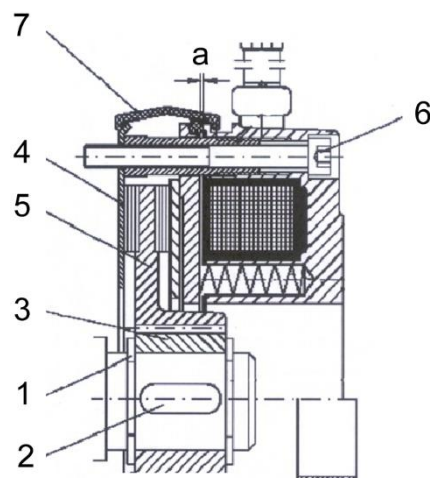

Illustration 12

### 12.3.2 Disassembly of the brake

Disassembly is performed in reverse order to the assembly.

### 12.3.3 Adjusting the air gap

View "X" on the brake.

- 1 Loosen the locking screws (6) by half a turn.
- 2 Turn the cap screws (8) into the magnetic body (9) anti-clockwise.
- 3 By turning the locking screws (6) clockwise, move the magnetic body (9) towards the anchor plate (10) using a feeler gauge until nominal air gap "a" is reached (see table).
- 4 Unscrew the cap screws (8) from the magnetic body clockwise.
- 5 Tighten the locking screws (6).
- 6 Check the air gap again and re-adjust if necessary.

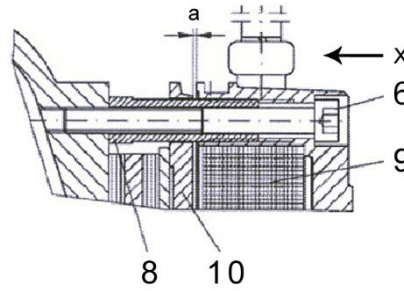

Illustration 13

### 12.4 Electronic overload protection - load limiter

Power consumption of the hoist motor is measured during lifting movement of a load by an adjustable power measuring device (overload guard). The setting is made via a separate relay for main and creep lifting speed. Power consumption of the motor is load-dependent and increases with the load. If the set value is exceeded, the relay responds immediately and switches the motor off via switching elements. After the overload protection has been activated the LOWER button must be pressed first so that the LIFT function can be activated again. Before lifting again the load must be reduced to the nominal load!



Illustration 14

#### Start (A)

First read nominal current from the motor type plate.

Start-up delay (START) has a setting range of 0 to 2 seconds. It should prevent the motor from being switched off immediately at start-up when start-up power is high. Setting is made at approx. 2 seconds (regulator in position completely right at 2s, display "1" (U/t) shines "green" until the start-up delay has expired.)

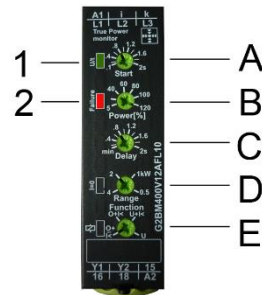

Illustration 15

#### Range (D)

Setting value must always be = or > as the existing power.

Nominal power	current
kW	A
0,5	0-3
1	0-6
2	0-9
4	0-12



Illustration 16

for larger power consumption, current converters are used

### Power (B) - Main lift

Turn the regulator totally to the right side at 120 %  
Lift the testing load and reduce the value of the potentiometer "B" (Power) slowly (turn left) until the relay actuates and cuts off the power so that the lifting movement stops.



Illustration 17

### Power (B) - Creep speed

Proceed as mentioned above but with the setting for creep speed.

In case of overload/overcurrent, the indicator "2" shines RED (Failure).

### Delay (C)

The value must always be set totally to the left side at 0s.

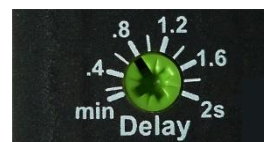

Illustration 18

### Function (E) - Overload

Turn the regulator totally to the left side at O+|<

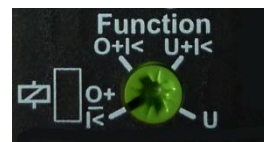

Illustration 19

## 12.5 Limit switch for wire rope path

### 12.5.1 Setting of the switching points

At first, adjust the cams for "lowering". Therefore lower the load to its lowest end position and adjust the cams.

- 1 Unscrew the screws of the cover and remove the cover.
- 2 Loosen the central screw (1)
- 3 Set the switching point of every cam disc (A+B) with set screw (2A+2B).
- 4 Tighten the central screw (1) again.
- 5 Install the cover again and make sure the rubber seal is placed correctly.

Make sure that 2-3 rope layers remain on the drum in the lowest load position.

Adjustment for "lifting" is done analogous.

Afterwards drive carefully to the end positions to check correct adjustment.

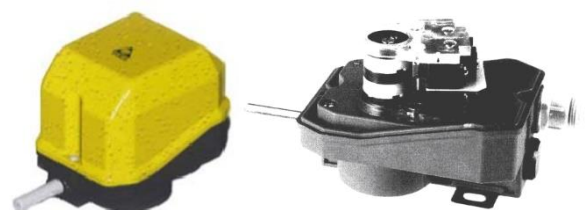

Illustration 20

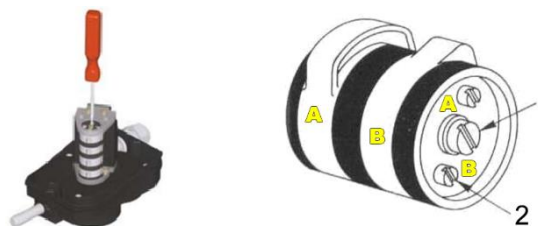

Illustration 21

## 12.6 Slack rope switch (as option)

### 12.6.1 Adjustment

Outline:

- 1 wire rope
- 2 rope drum
- 3 Spindle limit switch
- 4 pulleys
- 5 roller lever
- 6 eccentric
- 7 switching shaft

- Insert the wire rope between the two guiding pulleys and tightened it by the load.
- Release the locking screw at the eccentric
- Turn the eccentric until it gets contact to the tappet of the limit switch.
- Secure the eccentric with the locking screw.
- Switch on the winch in direction "Lowering" and relieve the wire rope.
- Repeat this procedure if necessary until the best switching point is found.

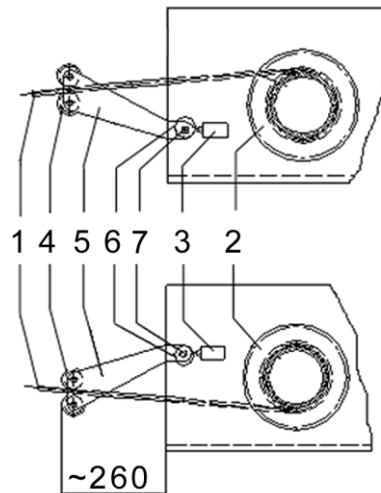

Illustration 22

## 13 Inspection

### 13.1 General Overhaul for motor-driven units

The accident prevention regulations VBG D8 must be observed and the measures to reach "safe working periods (S.W.P.)" according to FEM 9.755.

After the "theoretical working time D" has been elapsed, the owner/user must take motor driven devices out of operation and effect a General Overhaul.

Further use of the equipment is only allowed after a licensed qualified person has proved

- that further use is possible without doubt

and

- the conditions for further use have been determined

**These conditions have to be written down in the test book.**

The owner/user is responsible to make sure that these conditions are observed.

### 13.2 Periodic checks

Independently from the regulations of the individual countries, Gebuwin lifting devices must be checked at least yearly by a qualified person or licensed qualified person regarding its functional safety.

In Germany it is necessary to observe the accident prevention regulations BGV D6, BGV D8, BGR 500 as well as DIN 15020 (Basics for cable drives). In other countries, the above mentioned tests and the national safety regulations apply.

### 13.3 Wire rope

Adequate performance of the servicing and monitoring work acc. to DIN 15020 page 2 "Basics for cable drives – monitoring during use".

A visual check must be effected before every new work shift.

- Wear
- Deformation
- Fissures
- Corrosion

Report any damage immediately to the responsible person and exchange damaged or worn wire ropes and load tackles.

### 13.4 Inspection intervals

	on commissioning	daily checks	1st service after 3 months	inspection, service every 3 months	inspection, service every 12 months
Inspection of the equipment by a qualified person (periodic inspection)					X
Check screw connections	X				X
Check brake function	X	X			
check brake air gap (only for electric devices *)					X
check overload protection if existent					X
clean and lubricate the wire rope	X		X	X	
check wire rope and wire rope end fastenings for damage and wear		X			
check the load tackle and load hook for cracks and deformation					X
*) not for EX design					
Lubricate the toothed wheel of the drum Winches from 250 kg up					X

## 14 Service

### 14.1 Wire rope

Wire ropes have to be exchanged by new, original wire ropes if they show corrosion, fracture or if they are worn.

Checks:

- Fastening screws must be checked before commissioning and at least every 3 months, - tighten them if necessary.
- Kind and number of broken threads.
- Position of the broken threads
- Timing sequence of occurrence of breaks.
- Reduction of the wire rope diameter.
- Corrosion
- Abrasion
- Deformation
- Heat influence
- Operation time
- Wire rope fastening



#### **CAUTION!**

The wire rope must be replaced immediately should even one strand be broken.

### 14.2 Gearbox

The worm gear is maintenance free.

The teeth of the spur gear for winches from 250 kg pulling rope force and up must be re-lubricated at least once a year.

Lubricant recommended: grease Renolit FEP2

### 14.3 Electric motor

For the motor it is sufficient to keep the cooling airways clean and monitor the roller bearing and its lubrication status.

A high temperature fat must be used if the roller bearing is replaced.



#### **CAUTION!**

Brake linings and surfaces must always be clean and fat-free. Even very small amounts of dirt can reduce the braking moment considerably.

### 14.4 Lubricant selection

FUCHS	SHELL	ESSO	ARAL	MOBIL	CASTROL	KLÜBER
Renolin PG 220	Tivela S 220	Glycolube 220	Degol GS 220	Glygoyle 30	--	Klubersynt GH 6-220
Renolin PG 320	Tivela S 320	Glycolube 320	Degol GS 320	Glygoyle 320	--	Klubersynt GH 6-320
Renolit FEP 2	Alvania EP 2	Unirex EP 2	--	Mobilux EP 2	--	--
Renolin B10 VG32	Tellus Oil 32	--	--	--	--	--
Stabylan 5006	--	--	--	--	Optimol Viscoleb 1500	Klüberoil 4UH 1-1500

## 15 Trouble

Please pay attention to the following in case of problems:

- Troubles with the equipment must only be repaired by qualified personnel.
- Secure the unit against unintended operation start.
- Put up a warning note indicating that the unit is not to be used.
- Secure the working area of moving parts of the unit.
- Please read the chapter "Safety instructions".

Notes on the repair of faults are found in the following table.

For the repair of failures please contact our service department.



### **CAUTION!**

Trouble caused by wear or damage to parts such as wire ropes, chains, chain wheels, axes, bearings, brake parts, etc., must be remedied by replacing the parts with original spare parts.

## 16 Remedy

Problem	Cause	Remedy
Hoist motor does not run	No mains voltage	Check the mains connections
	Fuse burnt out	Replace the fuse
	Defective switching unit in the push button	Replace the switching unit
	Break in the control cable	see „problem brake does not release“
	Brake does not release	
	Defective switching unit in the push button	Replace the switching unit
Hoist motor runs – load is not lifted	Defect of capacitor (only for alternating current)	Replace the capacitor
	Overload protection is activated (with overload)	Reduce the load to nominal load
	Overload protection is activated (at a load =< nominal load)	Check settings and reset if necessary
Motor hums and uses excessive current	Defective coil	Motor must be repaired by a specialist
	Rotor is rubbing	
	Defect of capacitor (only for alternating current)	Replace the capacitor
	Brake does not release	See "problem brake does not release"
Damaged coil	Overload (mechanical or electrical)	Motor must be repaired by a specialist
Motor does not brake or has excessive after-running	Brake linings are worn or greasy	Brake lining must be changed completely
	Air gap is too large	Re-adjust the air gap
	Switching error after intervention in the electric circuit	Check brake connection acc. to the wiring diagram
	Brake rectifier defective	Replace brake rectifier
Brake does not release	Brake current relay defective	Replace brake current relay
	Brake coil is defective	Replace the brake coil
	Permissible air gap is exceeded due to worn out brake lining	Re-adjust the air gap and exchange the brake linings if necessary
	Power drop in the mains power line > 10%	Provide correct power supply voltage
	Motor or wiring short-circuit	Correct the short-circuit
Fuses burn out or motor contactor is triggered	Motor has a short-circuit in the body or windings	Have the problem corrected by a specialist
	Motor is incorrectly wired	Correct the wiring
	Wrong type of fuse	Replace the fuse with correct one



## 17 Decommissioning



### **WARNING!**

It is essential that the following points are observed in order to prevent damage to the equipment or critical injury when the device is being decommissioned:

It is mandatory that all steps for decommissioning the machine are carried out in the indicated sequence:

- First secure the working area for decommissioning, leaving plenty of space.
- Read the chapter "Safety instructions".
- Disassembly is carried out in reverse order to the assembly.
- Please make sure that all operating material is disposed of in accordance with environmental regulations.

### **17.1 Temporary decommissioning**

- Measures are as above.
- Also read the chapter "Transport and storage".

### **17.2 Final decommissioning/disposal**

- Measures are as above.
- After disassembly, ensure that the disposal of the equipment and any materials it contains is carried out in accordance with environmental regulations.

## **18 Additional documents**

### **18.1 Electric wiring diagrams**

Electric wiring diagrams are attached to the consignment or included in the terminal box.  
Except for units supplied without control.

### **18.2 Radio control (as option)**

Should the unit be fitted with radio control, a manual for radio control is attached to the consignment.

# G E B U W I N

## quality winches

Kijk op onze website [www.gebuwin.com](http://www.gebuwin.com) en YouTube pagina voor meer informatie over handlieren, hijsdavits, actuators en accessoires.

For more information about handwiches, swivel davits, actuators and accessories go to [www.gebuwin.com](http://www.gebuwin.com) or go to our YouTube page.

Weitere Informationen zu Handseil Winden, Schwenk-Davit, Antrieben und Zubehör finden Sie auf unserer Website: [www.gebuwin.com](http://www.gebuwin.com)

Pour plus d'informations sur les trueille a main, les bossoirs pivotants, les actionneurs et les accessoires, visitez notre website: [www.gebuwin.com](http://www.gebuwin.com)



*Scan to download all  
other documents*